

Cromartie

Temperature Programmer Handbook



www.cromartiehobbycraft.co.uk

At a Glance

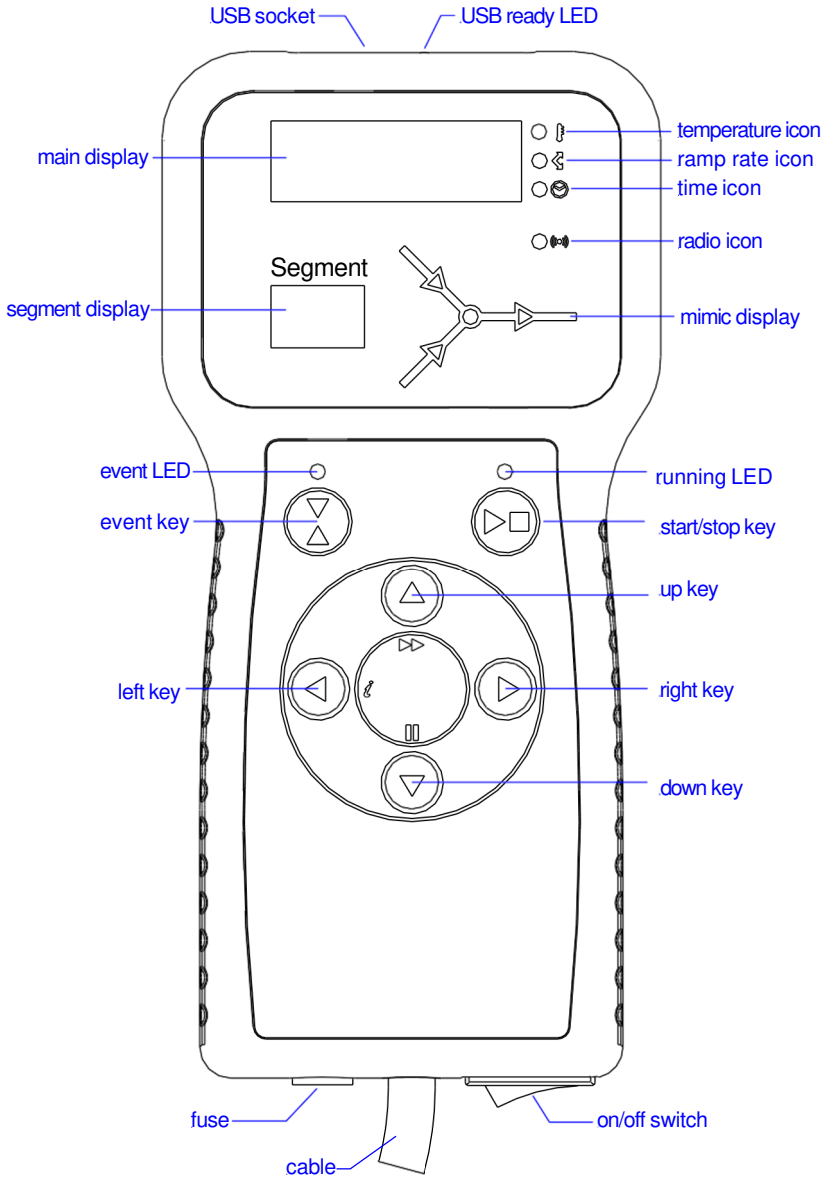

Quick Start Guide

Switch on & wait for kiln temperature display

To run a firing program set up previously press the ►■ key

To stop the firing at any time press the ►■ key again

To review firing data press the ► key to enter the programming mode

To change firing data press the ▲ & ▼ keys to change the displayed value

Use the ► key again as necessary to step to the next firing value or segment to be reviewed or changed

To mark the end of a program set a ramp rate to End with the ▼ key

To exit the programming mode either wait 20 seconds or press the ►■ key to start firing

If the keyboard is locked then press the ▲ & ▼ keys together & hold down for 5 seconds to unlock

Contents

At a Glance	2
Quick Start Guide	3
Contents	4
Features	5
Turning On	6
Programming	7
Control Relay Option	9
Firing	12
Cooling	13
Operating Notes	14
Adjusting While Firing	15
Error Messages	16
Sample Glass Programs	18
Sample Ceramics Programs	19
Other Features	20
WiFi & USB Datalogging Option	21
Installation	26
Characteristics	32

Features

- 32 programs each with 32 segments
- 1 controlled heating / cooling ramp + soak per segment
- Soak periods up to 99 hours 59 mins
- Ramp rates from 1 to 999°/hour + FULL
- Ideal for glass or ceramics use
- Programs can be altered while firing
- Program pause and advance facilities
- Keyboard lockable
- Delayed start facility - up to 99 hours 59 mins
- Power failure recovery
- Energy used display
- Setpoint display
- Alarm buzzer & alarm output
- Event/damper/fan control relay option
- WiFi + USB datalogger option
- °C/°F operation

Turning On



When turned on the ST215C performs a display test by lighting all of the display segments and illuminating all of the front panel indicator lamps.



The version number of the software embedded within the ST215C is now displayed. If you need technical support you might be asked for this code together with the serial number.



Next displayed is the thermocouple type setting. This should match the type of thermocouple fitted to the kiln and can be R, S, K or N type (r,S,H,n).



The final display will show the kiln temperature. All other lamps should be off.



If pressing any key causes LOC to appear then the keyboard has been locked. This is an anti-tamper feature. Press the ▲ & ▼ keys together & hold down for 5 seconds to unlock.



This now shows that the keyboard is UNLOCKED. To re-lock the keyboard press the ▲ & ▼ keys together & hold down for 5 seconds.

If any mimic panel lamps are on then the ST215C is firing. To stop the firing press the ■ key.



During firing the right-hand decimal point will light to show when heating power is being applied to the kiln.

SEGMENT



SEGMENT



Note: During power up the SEGMENT display shows the operating units (°C/°F) of the ST215C (Installer adjustable).

Programming

A firing segment

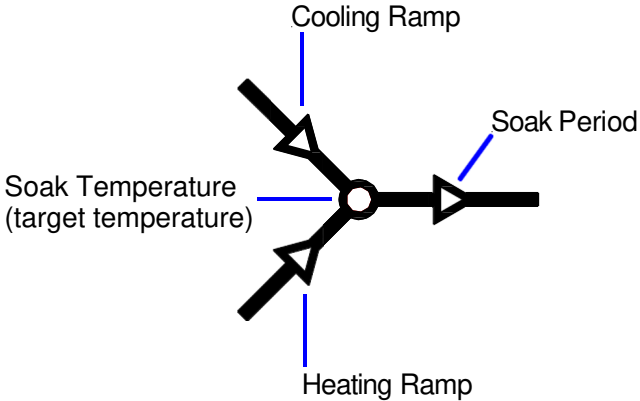

An ST215C firing segment comprises a ramp followed by a soak period. Two segments can be used for simple firing (biscuit firing for example) or several segments can be used per program for complex firing (crystal glazing or glass-making for example).

The ST215C ramps the kiln temperature at the required ramp rate until the kiln reaches the soak / target temperature. It then soaks (dwells) at the soak temperature for the soak period. It then runs the next segment until the end of the program is reached.

The ST215C is capable of both positive (heating) ramps and negative (cooling) ramps - as used in glassmaking for annealing. The type of ramp is clearly shown on the mimic display during firing.

The ramp rate is settable in the range 1°/hour to 999°/hour or FULL (full power) or End (end of program).

The soak / target temperature is settable over the range 0 to 1400°C (2552°F).

The soak period is settable over the range 00.00 (no soak) to 99 hours 59 mins.

Note: during soaking the ST215C display alternates every 15 seconds between kiln temperature and soak period remaining.

Altering a program



When not firing there are no indicators lit on the mimic panel, the run indicator is off and the display shows the current kiln temperature.

The settings can be reviewed by pressing the ► key.



The first push of the ► key flashes the program number display. The required firing program can now be selected with the ▲ & ▼ keys.

Note: holding down the ▲ or ▼ keys causes rapid change of the displayed value.



The next push of the ► key displays the ramp rate in the range End, 1-999°/HR or FULL. This can be altered with the ▲ & ▼ keys. The heating ramp or the cooling ramp indicator on the mimic panel will flash. End marks the end of the program. FULL heats or cools as fast as possible.



The next push of the ► key displays the soak temperature. This can be altered with the ▲ & ▼ keys. The soak temperature indicator on the mimic panel will flash.



The next push of the ► key displays the soak period in hours:minutes. This can be altered in the range 00:00 to 99:59 with the ▲ & ▼ keys. The soak period indicator on the mimic panel will flash.

SEGMENT

The next push of the ► key increments the segment number digit and firing data for the next segment can be entered.



Program data entry is terminated if End is selected for a ramp rate with the ▼ key. Program data entry is also automatically terminated if the maximum number of segments have been entered.

Note 1: available ramp rate displays are: End, 1 ... 999 & FULL. If End is shown but another segment is required then push the ▲ key to obtain the required ramp rate (in the range 1°/hr to 999°/hr). If maximum heating/cooling is required then push the ▲ key until FULL is displayed. To mark the end of the program push the ▼ key until End is displayed

Note 2: to exit programming without cycling through all of the above steps wait 20 seconds without pressing any keys - the ST215C will revert to the idle display. Alternatively press the ► key to exit programming and to begin firing immediately.

Note 3: the ◀ key can be used to reverse through the programming steps to correct errors or to exit programming mode.

Control Relay Option

Control Relay Configuration

The ST215C has an optional control relay that can be configured (see installation section) as: not used, an event output, a damper control output or a fan control output.

Event Output

The event output can be programmed to change state at the start of a ramp and also at the start of a soak period. Thus both ramp and soak events are possible. The event output is ON (relay contacts are closed) when the event lamp is lit. Prior to running a program the event output is OFF (relay contact is open). The event output status is stored within the firing program.

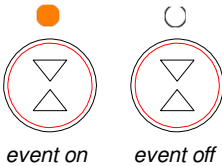

While programming either a ramp rate or a soak time the event output can be switched on or off by pressing the event key. The event output will be ON when the event lamp is on. The event output will be OFF when the event lamp is off. The event lamp also shows the status of the event output when the is running a program.

Damper Output

To enter the damper temperature configuration menu press the ◀ key and the ▶ key down together while the is not running a program (firing indicator not lit).

Note: in the sequence below if no key presses are detected within 30 seconds the ST215C will exit the menu and damper temperature changes will not be saved.



- The damper close temperature prompt is shown. Release the ◀ & ▶ keys.
- Press the ▶ key.



- The damper close temperature is now shown.
- Adjust with the ▲ & ▼ keys (hold down for acceleration).
- Press the ▶ key.



- The damper open temperature prompt is now shown.
- Press the ▶ key.



- The damper open temperature is now shown.
- Adjust with the ▲ & ▼ keys (hold down for acceleration)
- Press the ▶ key.

The ST215C will now reset and the new damper control temperatures will be stored.

Note: in the sequence above it is important that the ▶ key is pressed a total of 4 times else changes will not be saved.

Damper Operation

Prior to firing the damper will be open. During firing, when the kiln reaches the damper close temperature, the damper will close. The event indicator will be on.









At the end of the firing and when the kiln has cooled naturally to the damper open temperature, the damper will open. The event indicator will be off.

Note: The event switch has no function for damper operation

Fan Output

To enter the fan temperature configuration menu press the ◀ key and the ▶ key down together while the is not running a program (firing indicator not lit).

Note: in the sequence below if no key presses are detected within 30 seconds the ST215C will exit the menu and fan temperature changes will not be saved.

	<input type="radio"/> 	The fan start temperature prompt is shown.
	<input type="radio"/> ◀	Release the ◀ & ▶ keys.
	<input type="radio"/> ▶	Press the ▶ key.
	<input checked="" type="radio"/> 	The fan start temperature is now shown.
	<input type="radio"/> ▲	Adjust with the ▲ & ▼ keys (hold down for acceleration).
	<input type="radio"/> ▼	Press the ▶ key.
	<input type="radio"/> 	The fan stop temperature prompt is now shown.
	<input type="radio"/> ◀	
	<input type="radio"/> ▶	Press the ▶ key.
	<input checked="" type="radio"/> 	The fan stop temperature is now shown.
	<input type="radio"/> ▲	Adjust with the ▲ & ▼ keys (hold down for acceleration)
	<input type="radio"/> ▼	Press the ▶ key.

The ST215C will now reset and the new fan control temperatures will be stored.

Note: in the sequence above it is important that the ▶ key is pressed a total of 4 times else changes will not be saved.

Fan Operation

Prior to firing the fan will be off. During firing the fan will start when the kiln temperature has risen to the fan start temperature.

The fan will remain on until the kiln temperature has risen to the fan stop temperature. The fan then turns off and remains off.

The event indicator is turned on while the fan is running.

Note: the event switch has no function for fan operation

Firing

To start a firing press the ►■key. The running (firing) indicator lamp will flash.



With the firing indicator flashing an optional start delay up to 99 hours: 59 minutes can be entered with the ▲ & ▼ keys.

After 5 seconds, or immediately if the ►■key is pressed again, the firing will commence and the firing indicator lamp will remain lit.

To stop the firing prematurely at any time press the ►■key again. The firing indicator lamp will go out.

Hint: it is good practice to check that the program is correct by pressing the ► key & checking the program number & program contents before pressing the ►■ key to start a firing. It is also a good idea to have a written record of the contents of the firing programs kept and displayed near the kiln especially if there is more than one user of the kiln.

Note: during ramping the ST215C will perform either controlled heating or controlled cooling - as indicated on the mimic display. During soaking the ST215C display alternates every 15 seconds between kiln temperature and soak period remaining. At the end of each segment the segment number display will be incremented.

Information: The ST215C operates by calculating the amount of energy required by the kiln every 30 seconds (this period is installer adjustable). If for example 40% of full energy is required to maintain a particular ramp rate or a particular soak temperature then the ST215C will apply heating power to the kiln for 12 seconds every 30 seconds. The kiln heating indicator will light for 12 seconds every 30 seconds. If the kiln has a contactor then a loud click will be heard both when the kiln heating indicator lights up and when it goes out. If full heating power is required then the kiln heating indicator will remain lit. If full cooling is required the kiln heating indicator will remain off.

Cooling

Upon completion of firing the ST215C lights all lamps on the mimic display and the kiln is allowed to cool naturally.

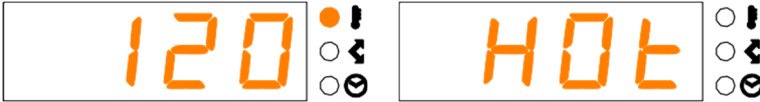

While the kiln temperature is above 40°C the display alternates every 5 seconds between the kiln temperature and HOT.



When the kiln has cooled to less than 40°C the display alternates every 5 seconds between the kiln temperature and End.

To return the ST215C back to idle condition ready for the next firing press the ► key (or turn off the power to the instrument).

Operating Notes

Kiln too slow

If the ST215C is programmed to heat the kiln at a faster rate than the kiln is capable of then the ST215C will turn on full power then wait until the kiln temperature has risen to the correct temperature before proceeding to the next ramp or soak segment.

Likewise if the ST215C is programmed to cool the kiln at a faster rate than the kiln is capable of then the ST215C will apply zero power then wait until the kiln has cooled to the correct temperature before proceeding to the next ramp or soak segment.

Heating & Cooling Ramps

The ST215C is capable of controlled ramps for both heating and cooling. The type of ramp required is determined by comparing the required soak temperature to the soak temperature in the previous segment and is shown on the mimic display.

▶■ Key Operation

If the ▶■key is pressed during a firing then the firing will be halted (not paused). Pressing the ▶■key again will cause the ST215C to restart the firing from the beginning. The ST215C will look at the current kiln temperature and if this is greater than the required soak temperature then the ST215C will automatically *cool* from current temperature to the soak temperature. This may not be what is desired so the ▶■key should only be used to halt the firing in an emergency.

The program can be paused or program data can be changed while the is firing (see next section). This is a better option than using the ▶ key. The▶program advance feature is however available to recover quickly from ▶ key operation if required.

Memory

All programs & necessary data are remembered when the ST215C is turned off. In the event of power failure during firing the ST215C will automatically resume firing when power is returned (this feature can be disabled: see Installation section).

Delayed Start

By default the delayed start time period is initialised to 00:00 for each firing. The ST215C can however be configured to remember the delayed start time period (see Installation section).

Adjusting While Firing

Firing values can be adjusted while the ST215C is firing. Also there are program pause and program advance features that are particularly useful for glass work.

Adjusting Firing Values

While firing operate the ► key to select the required parameter as shown by a flashing lamp on the mimic display. The firing value is shown on the main display and can now be adjusted with the ▲ & ▼ keys in the usual way. The contents of the current segment or any segment still to be executed can be changed. Firing will still carry on as normal while these changes are being made. The ST215C will return to its normal running display 20 seconds after key presses cease (or immediately after End is displayed).

Changes made to programs in this way are stored and are used for subsequent firings.

Program Advance Facility

While firing press and hold down the ▲ key for 3 seconds to obtain the ►► (advance) function. The ST215C will sound a short beep and the executing program will immediately advance one step as indicated by lamps on the mimic panel. The effect of this is as follows:-

If ramping then the ST215C will switch to soak at the current kiln temperature. If soaking then the ST215C will advance to the ramp in the next segment if any, or else it will end the firing.

Changes made to the operation of the ST215C in this way are temporary and are not stored.

Program Pause Facility

While firing press and hold down the ▼ key to obtain the || (pause) function. The ST215 will sound a short beep and the executing program will pause at the current kiln temperature. To release the pause repeat the above action.



While paused, the kiln temperature display will alternate periodically with a scrolling PAUSED display and a beep will be sounded.

WARNING - PROGRAM PAUSE

The program pause facility should be used with care. Program execution is suspended and the kiln will be held at its current temperature. If left too long at high temperatures kiln damage could result. Pause will automatically release after an Installer-defined time period (default: 2 hours - see Installation section).

Error Messages

If the ST215C detects a problem the buzzer will sound and an error message will be displayed. This error message will alternate with a display of kiln temperature. The segment number display will show where the error occurred.

To obtain more information on the error press the ◀ key. The first press will display the maximum temperature reached in the firing. The second press will display the length of time that the error has been present. The buzzer will mute.



Heating error. The kiln temperature is not increasing as required. The kiln has been on full power for 15 minutes but the temperature has not increased by at least 2°C.

Possible causes: kiln door or lid not closed properly or door switch faulty or needs adjusting. Heater element open circuit or elements too old. Electrical power phase failure or contactor failure.



Thermocouple or thermocouple wiring open circuit. Get thermocouple and wiring checked. Replace thermocouple if necessary.



Thermocouple reversed (kiln temperature apparently less than -40°C). This is an installation fault. Get wiring checked.



Cooling error. The kiln has been on zero power for 30 minutes but the kiln temperature has not fallen by at least 1°C.

Possible causes: contactor failure (contacts welded?) or thermocouple connection intermittent or high resistance.



Kiln temperature overshoot. The kiln temperature exceeds the desired temperature by a preset limit as shown below:-

Desired Temperature

Less than 100°C

More than 100°C but less than 200°C

More than 200°C but less than 600°C

More than 600°C

Overshoot allowed

+60°C

+50°C

+30°C

+20°C



Maximum firing time exceeded. The length of the firing has exceeded an installer selectable limit.



Maximum room temperature exceeded. The internal temperature of the ST215 has exceeded an installer selectable limit.

Possible causes: kiln room vent fan failure, kiln room too small, ventilation grills blocked, damper or bung left open, mounted too close to kiln.

All these error messages cause the ST215C to terminate the firing. The alarm buzzer will sound once per second. To reset the ST215C turn off the power to the instrument and have the fault investigated and rectified by your installer or kiln service engineer.

Note: these error messages are provided to detect kiln faults and so offer some protection to the kiln.

Technical note: these error messages will cause the alarm relay to open.

Firing Program Errors



Program Error. This error message is displayed if a potential error is detected within the firing program when the ►■ key is pressed to start a firing. The alarm buzzer will sound 3 times and the segment display will show the

suspect segment number. To clear this error press the ► key. The ST215 will now enter programming mode to allow the suspect program to be viewed and altered if necessary. If a fault is found then correct it. If no fault is found then press the ►■ key again to force the firing program to start. A potential programming error is defined as a very low ramp rate to a very low temperature. Such a programming fault might cause very long firing times with potential kiln damage.

Sample Glass Programs

The ST215C is provided pre-programmed with the glass firing programs below. These programs may be modified or over-written as required.

Program No.	Program Description	Seg 1 Ramp Rate °C/hr	Seg 1 Soak Temp °C	Seg 1 Soak Time hr:mn	Seg 2 Ramp Rate °C/hr	Seg 2 Soak Temp °C	Seg 2 Soak Time hr:mn	Seg 3 Ramp Rate °C/hr	Seg 3 Soak Temp °C	Seg 3 Soak Time hr:mn	Seg 4 Ramp Rate °C/hr	Seg 4 Soak Temp °C	Seg 4 Soak Time hr:mn	Seg 5 Ramp Rate °C/hr
1	4-6mm Float Glass Fuse	150	538	00:10	FULL	840	00:20	FULL	538	00:45	182	427	00:15	End
2	4-6mm Float Glass Slump	150	538	00:00	200	700	00:15	FULL	538	00:15	182	427	00:00	End
3	6mm Bullseye™ Fuse	222	677	00:30	333	795	00:10	FULL	482	01:00	83	371	00:01	End
4	6mm Bullseye™ Slump	167	640	00:10	FULL	482	01:00	56	371	00:01	End	-	-	-
5	6mm Spectrum System 96™ Fuse	200	500	00:00	FULL	804	00:12	FULL	540	00:40	150	510	00:20	End
6	6mm Spectrum System 96™ Slump	155	704	00:20	FULL	540	01:30	FULL	510	00:10	26	371	00:00	End
7	Bottle Firing Cycle	170	510	00:00	250	780	00:10	FULL	510	01:00	70	400	00:30	End
8	Low Stain	200	570	00:10	FULL	516	00:30	100	300	00:00	End	-	-	-
9	High Stain	200	665	00:10	FULL	550	00:20	FULL	516	00:30	100	300	00:00	End

Sample Ceramics Programs

The ST215C is provided pre-programmed with the ceramics firing programs below. These programs may be modified or over-written as required.

Program Number	Program Name	Seg 1 Ramp Rate °C/hr	Seg 1 Soak Temp °C	Seg 1 Soak Time hr.mn	Seg 2 Ramp Rate °C/hr	Seg 2 Soak Temp °C	Seg 2 Soak Time hr.mn	Seg 3 Ramp Rate °C/hr
11	Slow Bisque	60	600	00.00	FULL	1000	00.00	End
12	Normal Bisque	100	600	00.00	FULL	1000	00.00	End
13	High Bisque	100	600	00.00	FULL	1140	00.00	End
14	Brush-on Earthenware Glaze 1000°C (Cone 6)	100	300	00.00	FULL	1000	00.00	End
15	Standard Earthenware Glaze 1100°C	100	300	00.00	FULL	1100	00.00	End
16	Earthenware High Temperature Glaze 1140°C	100	300	00.00	FULL	1140	00.00	End
17	Mid-Range Stoneware Glaze 1200°C	100	300	00.00	FULL	1200	00.00	End
18	Standard Stoneware Glaze 1260°C (see note)	100	300	00.00	FULL	1235	00.00	End
19	Onglaze 780°C	100	400	00.00	FULL	780	00.00	End
20	Lustre 750°C	100	400	00.00	FULL	750	00.00	End

Note

It has been found that a kiln will give greater heat work as the temperature increases. Therefore to achieve a stoneware firing of cone 8-9 we suggest setting the final soak temperature to 1235°C. A slight adjustment can then be made after the first firing. It should be remembered that kiln cones are indicators of temperature and the effects of faster or slower firings may cause extreme variations in the end result. This is known within ceramics as "heatwork". Cones are measures of heatwork and it is strongly recommended that cones are always used in conjunction with a kiln to appreciate the differences between heatwork and temperature indicated by the . Stoneware firings will also demonstrate the greatest potential differences between heatwork and indicated temperature.

Other Features

Energy Used & Setpoint Displays

Operate the ◀ key at any time to show the amount of electrical energy used in kWh. If pressed during a firing it shows the energy used so far. After a firing it shows the total energy used for that firing. This information is stored while power is off and is only reset to zero when a new firing is started. If the value displayed is always 0.0 then the kiln power rating has not been configured - see the Installation section of this handbook.

Operating the ◀ key a second time shows the current set-point (the temperature which the ST215C is currently trying to achieve).

Keyboard Lock Facility

The keys on the ST215C can be locked so that pressing them has no effect. This is an anti-tamper feature used to ensure that the operation of the ST215C or the program data cannot be altered by un-authorised people. The ST215C can be locked when it is idle (not firing) or while it is firing. It cannot be locked while it is being programmed.



Press the ▲ & ▼ keys together & hold down for 5 seconds to lock.



Press the ▲ & ▼ keys together & hold down for 5 seconds to unlock.

Power Failure Recovery

If power fails during firing then the ST215C recovers as follows:-

For power failure during start delay the ST215C times off the remaining start delay when power returns. For power failure during ramping the ST215C continues the ramp it was previously executing. For power failure during soaking the ST215C ramps back up to soak temperature at the correct ramp rate then applies the remaining soak period. This recovery scheme can be disabled if required (see installation section) - the ST215C will then lock up with FAIL displayed and kiln off in the event of power failure.

WiFi & USB Datalogging Option

This option (if fitted) allows for remote monitoring, datalogging and program loading by WiFi. It also has a USB connector to give local data logging, configuration and maintenance by USB FLASH memory “thumb” drive.

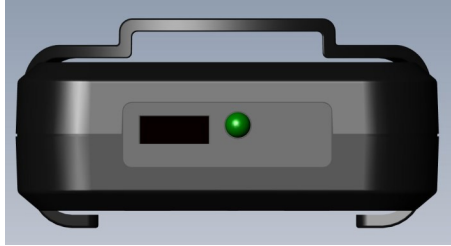

 The radio icon lamp on the front panel flashes when the ST215C is paired to a WiFi network and is sending or receiving information.

WiFi Configuration

To access the over an internet connection go to www.staffordinstruments.co.uk then click on the “MY ” link. Follow the on-screen instructions. One or more s can be registered to a user account. If you haven't already done so then you will first need to create a user account then register your .

USB Functions

The main USB function is to provide a time stamped datalogging facility. The log files created are in CSV format which can be read directly into a Microsoft Excel spreadsheet. User program data and or configuration data can also be read into the . Con- troller firmware updates are also possible.

The USB socket and associated green “Drive Mounted” LED are mounted on the top panel of the . A dust plug is provided for when a USB drive is not fitted.

FLASH Memory Drive Specification

These can be either USB1, USB2 or USB3 drives (USB3 drives have a blue insulator). The drives must be formatted as FAT32 or FAT16 (not NTFS or ExFAT). The module has been tested with several makes of drive up to size 256Gbytes. If the green LED next to the USB connector illuminates then the inserted FLASH drive is acceptable.

The drive can be inserted at any time (with the either on or off). It can also be removed at any time - but preferably not while the is writing data to the drive. The green LED will turn off when the drive is removed.

Time of day Clock Function

This datalogger module incorporates an accurate battery backed date and time of day clock. It compensates for leap years. It does not automatically compensate for day-light saving in summer and winter. This clock is used to time stamp data within the datalogger files. It is also used to date and time stamp the actual file. Note: the date and time stamp of the file is the time the file was last written to (not the time when the file was first created). The (replaceable) clock battery (CR1632) is sized to last at least 10 years.

Clock Adjustment

With the turned on and not firing: press and hold down the ◀ (left) key for 5 seconds.

You are now in date setting mode. The date is shown in YY.MM.DD format (2020.05.28 illustrated):-

20.05
28

Navigate to the flashing digit with the ▶ or ◀ key. Change the flashing digit with the ▲▼ keys. Move onto the next digit with the ▶ key.

Move to the time setting mode by pressing the ▶ key from the flashing day display. The time is now shown in HH.MM.SS format (09:15:20 illustrated):-

09.15
20

Navigate to the flashing digit with the ▶ or ◀ key. Change the flashing digit with the ▲▼ keys. Move onto the next digit with the ▶ key. Leave the time setting mode either by waiting 15 seconds or by pressing the ▶ key from the flashing seconds display.

Datalogging

Datalogging commences when a firing is started. Datalogging finishes when the firing is complete and when the kiln has cooled to 100°C. A file: LOGnnn.CSV is created on the FLASH drive. The first file to be created will be LOG000.CSV. Subsequent firings will generate LOG001.CSV ... up to LOG999.CSV. Only 1000 log files are allowed. It is best to move the LOG files to another storage disk after just a few firings—because it takes about 1 second to index each existing file on disk before a new file can be created. So for example if there are files LOG000.CSV to LOG100.CSV on disk there would be a delay of just over 100 seconds before LOG101.CSV could be created and logging could be commenced.

The files created are in "Comma Separated Variable" (CSV) ASCII format and can be directly imported into Microsoft Excel Spreadsheets.

Logging Interval

This can be adjusted over the range 5 to 300 seconds (default 60 seconds) using parameter P50 with the in configuration mode. Please see the Installation Instructions section of this document for details.

Log File Format

This is illustrated on page 23 of this document.

Year	Month	Day	Hour	Min	Sec	Kiln Temp	Setpoint	Ambient Temp	Program	Segment	Event	Status
2020	6	20	13	17	45	148.4	150.1	22.6	1	1	0	HEATING RAMP
2020	6	20	13	18	45	148.2	152.6	22.9	1	1	0	HEATING RAMP
2020	6	20	13	19	45	148.2	155.1	23.2	1	1	0	HEATING RAMP
2020	6	20	13	20	45	148.2	157.6	23.5	1	1	0	HEATING RAMP
2020	6	20	13	21	45	148.3	160.1	23.9	1	1	0	HEATING RAMP
2020	6	20	13	22	45	148.3	162.6	24.1	1	1	0	HEATING RAMP
2020	6	20	13	23	45	152	165.1	24.4	1	1	1	HEATING RAMP
2020	6	20	13	24	45	152	167.6	24.9	1	1	1	HEATING RAMP
2020	6	20	13	25	45	152.1	170.1	25.1	1	1	1	HEATING RAMP

Note

The "Event" field shows "1" when the optional damper / fan / event relay is energised.

For damper operation this indicates damper closed

For fan operation this indicates fan on

For event operation this indicates event active

In all cases the event LED above the event key on the front panel will be illuminated

The "Event" field shows "0" when the optional damper / fan / event relay is de-energised.

The event LED above the event key on the front panel will be off.

Status Field within Log File

The Status field within the log file format can show the following:-

"DELAYING",
"HEATING RAMP",
"HEATING RAMP PAUSED",
"COOLING RAMP",
"COOLING RAMP PAUSED",
"SOAKING",
"SOAKING PAUSED",
"COOLING",
"COOL",
"ERROR" + error number (0 to 9),
"POWER FAILED",
"PAIRING"

PROGRAMS.TXT

This file (if it exists on the drive) will be read only when the is powered up. So insert the drive while the is not powered. Then apply power to the .

This file changes the contents of the user programs using the following file format (one segment per line):-

Program number,segment number,ramp rate,temperature,soak time,event flag

So for example to put a simple firing program in program location 7 such as:-

Segment 1: 50°C/hr to 120°C then soak 60 minutes
Segment 2: 150°C/hr to 600°C then soak 0 minutes
Segment 3: FULL to 1250°C then soak 15 minutes
Segment 4: End

The contents of PROGRAMS.TXT would be:-

7,1,50,120,60,0
7,2,150,600,0,0
7,3,1000,1250,15,0
7,4,0,0,0,0

Notes:-

- (1) Out of range values will not be stored.
- (2) The last line of the program should have "0,0,0,0" (as shown above) to mark the end of the program.
- (3) The "event flag" item on the end of each program line should be set to 0 if the event relay option is not fitted to the .

If the event relay option is fitted to the then the event flag can have the following values:-

<u>Event flag</u>	<u>While ramping</u>	<u>While soaking</u>
0	Event relay OFF	Event relay OFF
1	Event relay ON	Event relay OFF
2	Event relay OFF	Event relay ON
3	Event relay ON	Event relay ON

It is best to store this file on a separate drive and remove it from the after use. In this way unnecessary reconfiguring is avoided the next time the is powered on. This drive can be used to re-configure multiple s.

CONFIG.TXT

This file (if it exists on the drive) will be read only when the is powered up. So insert the drive while the is not powered. Then apply power to the con- troller.

This file changes the configuration using the following file format (one item per line):-
Configuration Parameter Number, Configuration Parameter Value

So for example to change the settings for a datalogger sample interval of 60 seconds, with "K" type thermocouple, with a maximum user temperature of 1050°C and with a kiln power rating of 3.0kW:-

The contents of CONFIG.TXT would be:-

```
50,60  
0,0  
2,1050  
14,30
```

Note: out of range values will not be stored (ignored).

Note: refer to the Installation Section for a full list of configuration parameters.

It is best to store this file on a separate drive and remove it from the after use. In this way unnecessary re-configuring is avoided the next time the is powered on. This drive can be used to re-configure multiple s.

Firmware Updates

If a firmware update is required then this can be requested by email. If an update is available then this will be sent to you as an email attachment together with instructions on how to load the update.

Installation

Safety Warnings



DO NOT OPEN
(NO USER SERVICEABLE
PARTS INSIDE)

WARNING

**ISOLATE KILN & PROGRAMMER FROM ELECTRICAL
SUPPLY BEFORE ATTEMPTING INSTALLATION OR
REPAIR WORK**

Installer Information

Installation Category: II
Pollution Class: 2

100-240V ~ 50/60HZ 1.0A

Fuse: 3.15A Anti-surge
20mm ceramic HRC



IP50

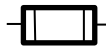

EMC

To meet Electromagnetic Compatibility requirements the lead should not exceed 3.0m in length.

This instrument is designed for use mainly in Domestic, Commercial & Light Industrial environments where electromagnetic interference may cause a loss of accuracy of the displayed temperature reading of up to 3°C. Specified accuracy will be restored when the interference is removed.

Mounting

Mounting Location

Mount the instrument on a suitable vertical surface which will not get hot. Choose a position where the instrument is not exposed to direct heat from the kiln - especially when the kiln door or lid is open.

Wall Mounting Bracket

This is a 'holster' style ABS moulded bracket which can be attached with 2 screws. The bracket mounting holes are spaced 70mm. The instrument can be removed from this bracket for in-hand programming if required.



Contactor Coil Suppress

The coil of the each kiln contactor **should be suppressed** with an RC suppressor. The RC suppressor must be connected directly across the coil terminals on the contactor. Suitable proprietary RC suppressors are often available from contactor manufacturers as add-on blocks.

A suitable RC suppressor with insulated wire leads (fly leads) is the Okaya Electric XEB1201B.

Connecting Lead

The ST215C is fitted as standard with a connecting lead and plug. The lead lengths can be either 2m or 3m. The plug type will one of the four shown.

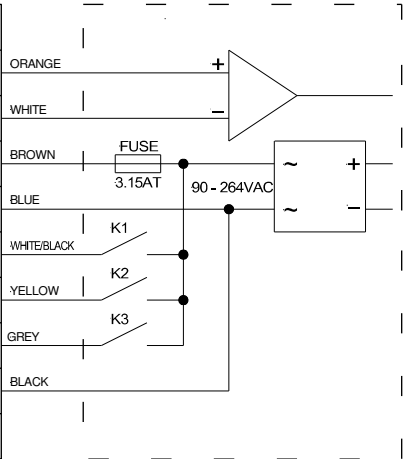

Han7D	Han12Q	CPC14	Han15D	
3	11	1	B5	Thermocouple +ve
4	12	2	C5	Thermocouple -ve
5	5	8	A1	Mains Supply (L)
2	6	9	B1	Mains Supply (N)
6	1	14	A3	Heating Control Output (L)
7	2	12	C3	Safety Control Output (L)
-	3	7	B2	Event/Damper/Fan Control Output (L)
1	-	13	B3	Control Output Neutral (N)
E	E	11	Shell	Earth

View on pins

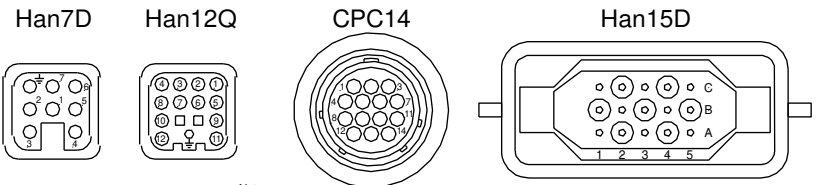

Note
The wiring of the CPC14 connector varies between kiln manufacturers. ROHDE wiring is shown.

Configuring

To enter configuration mode power down the ST215C. Press and hold down both the **↵** key & the **▶** key while powering up the ST215C.

- **!** When the thermocouple type is displayed release the **↵** key & the **▶** key.
- **◀**
- **⊖**

- **!** The first setup parameter number is now displayed (flashing 00). Refer to the code tables overleaf for a description of the available configurable parameters.
- **◀**
- **⊖**

- **!** Change the parameter number with the **▲** & **▼** keys. To display the parameter value press the **▶** key.
- **◀**
- **⊖**

- **!** The parameter value can now be altered with the **▲** & **▼** keys. To select another parameter press the **▶** key.
- **◀**
- **⊖**

Pressing both the **↵** key & the **▶** key at any time causes the configuration parameters to be stored. The instrument will then reboot.

- **!** *Note: in the above sequence if no key presses are detected for 30 seconds the instrument will time out and exit configuration mode **without saving any changes**. The buzzer will sound for 3 seconds.*
- **◀**
- **⊖**

ERROR MESSAGES

Certain error messages can be disabled by the use of configuration parameters. Error messages should normally be left enabled. Error messages should only be disabled as a short term measure - to diagnose kiln problems for example.

The alarm output contact closes at the start of a firing and opens when the firing is complete. If an error message is generated the firing is terminated, the alarm buzzer sounds and the alarm output contact opens. This output is usually used to drive a secondary (policeman) contactor to isolate power to the kiln elements.

Error messages are provided to detect kiln faults and so offer some protection to the kiln. For increased protection the use of a heat fuse or other independent over-temperature trip is recommended. For maximum protection an independent thermocouple, trip & heater contactor circuit should be used.

Note: Power fail recovery may need to be disabled if un-attended firing is not allowed.

Setup Parameters

<u>No.</u>	<u>Function</u>	<u>Min.</u>	<u>Max.</u>	<u>Default</u>	<u>Notes</u>
0	Thermocouple type	0	3	2	0=K, 1=N, 2=R, 3=S
1	Error 1 enable	0	1	1	0=disabled, 1=enabled
2	Max. user temperature	100	1400	1320	°C
3	Display brightness	0	6	3	0=dim, 6=bright
4	Error 4 enable	0	1	1	0=disabled, 1=enabled
5	Error 5 enable	0	1	0	0=disabled, 1=enabled
6	Error 6 firing hours trip	10	1000	1000	1000=disabled
7	Room temperature trip	30	71	50	°C. 71=disabled
8	Power fail recovery enable	0	1	1	0=disabled,1=enabled
9	Paused time limit (hours)	1	11	2	11=disabled
10	Set point offset	-99	99	0	°C
11	Proportional band	1	999	55	°C
12	Integral time (seconds)	0	9999	200	0=disabled
13	Differential time (seconds)	0	999	10	0=disabled
14	Kiln element power	0	9999	0	1 unit = 0.1kW
43	Engineer lockup on error	0	1	0	0=disabled, 1=enabled
44	Control cycle time	5	120	30	Seconds
45	Event/Damper/Fan (RL3) Function	0	3	0	0=off, 1=event, 2=damper, 3=fan
46	Remember start delay	0	1	0	0=forget, 1=remember
47	Skip start delay after power failure	0	1	0	0=resume delay, 1=skip delay
50	USB Data Logging Sample Period	5	300	60	seconds
55	Disable setup password protection	0	1	1	0=enabled, 1=disabled
60	Operating units °C/°F	0	1	0	0=°C, 1=°F

Note: The setup parameters shown thus are freely adjustable. The other setup parameters might be password protected - contact supplier.

Configuration Notes

<u>Parameter</u>	<u>Note</u>
10	Setpoint offset: This is added to the setpoint defined by the user program. This will normally be left at 0.
43	Engineer lock-up on error: If this feature is enabled then errors cannot be cleared by cycling the power to the i.e: cannot be cleared by the user. This forces an engineer call out to determine the cause of the error and a repair to be implemented.
46	Remember start delay: By default this feature is disabled and the sets the initial value for start delay to 00:00. If enabled the remembers the user entered start delay from the previous firing (useful for repetitive overnight firings). In either case the actual start delay can be edited by the user.
47	Skip start delay after power failure: By default this feature is disabled and in the event of a power failure while executing the start delay, the times off the remainder of the start delay when power is restored. If enabled the immediately starts firing when the power is restored. Note: the does not contain a real time clock and so does not know how long the power has been off.
60	Operating Units °C/°F: When units are changed the will reload its default set of programs (in either °C or °F units as required). Warning! - this will over-write any existing firing programs!

Characteristics

Electrical

Power supply

Voltage range: 90 - 264VAC
Frequency: 50/60Hz
Power: 4VA (max) Switched outputs 125VA

Fuse: 3.15A slow-blow HRC
20mm x 5mm ceramic

Control Relays (2 or 3)

Contact type: SPST NO
Switched Line voltage O/P @500mA max
(for contactor driving)

Thermocouple

R,S,K & N type.

Lead & Connector

2m or 3m flexible grey polyurethane lead
Fitted with either Han7D, Han12Q, Han 15D
or CPC14 connector

Environmental

Operating temperature range: -10°C to +55°C
Storage temperature range: -10°C to +55°C

Error Handling

Thermocouple failure detection
Thermocouple reversal detection
Heater failure detection
Kiln over-temperature detection
Room over-temperature detection
Lock-up on error facility
Firing run time hours limiter
User program check
Alarm buzzer

Other

Keyboard lock facility & indication
Kiln heating indicator
Program running indicator
Energy used display

Wall Bracket

Material: ABS flame retardant UL 94V-0
Colour: Black RAL9011
Fixing slot centres (vertical): 70mm
Fixing slot size: 8mm x 4mm

Temperature

Temperature setting

Range: 0 to 1400°C (R/S) 0 to 1200°C (K/N)
Resolution: 1°C

Control Accuracy

P.I.D. Control
Reading accuracy: $\pm 0.25\%$ FSD ± 1 digit

Time

Start delay range: 00:00 to 99hr 59min
Soak time range: 00:00 to 99hr 59min
Resolution: 1 min

Ramps

Ramp rate: 1 to 999°/hour or FULL
Ramps can be heating or cooling

Enclosure

Material: ABS flame retardant UL 94V-0
Sealing: IP51
Size: 80/68mm(W), 165mm(L), 28mm(D)
Colour: Black/Dark Grey
(RAL9011/RAL7012)

Weight

Instrument + cable + wall bracket: 0.50kg (max)

Packaging

Packaged size: 248 x 185 x 58mm
Packaged weight: 0.570kg (max)



This instrument complies with
Council Directive 89/336/EC
(EMC) & Council Directive
2006/95/EC (safety)



Council Directives 2002/96/EC & 2003/108/EC
The crossed out bin symbol, placed on
this product, reminds you of the need to
dispose of the product properly at the
end of its life. Electrical & Electronic
Equipment should never be disposed of
with general waste but must be sepa-
rately collected for proper treatment. In this
way you will assist in the recovery, recycling &
reuse of many of the materials used in this
product.